

Central and West Asia Department (CWRD)

Presentation to the
2006 Orientation Program for DMC Officials

Sean M. O'Sullivan
Director, Infrastructure
and Officer-In-Charge, CWRD
7 September 2006

The logo for the Asian Development Bank (ADB), consisting of the letters 'ADB' in a white serif font on a dark blue square background.

ADB

CWRD Clients

- Afghanistan
- Armenia
- Azerbaijan
- Kazakhstan
- Kyrgyz Republic
- Pakistan
- Tajikistan
- Turkmenistan
- Uzbekistan



Central and West Asia Region

- Population Size 262 million

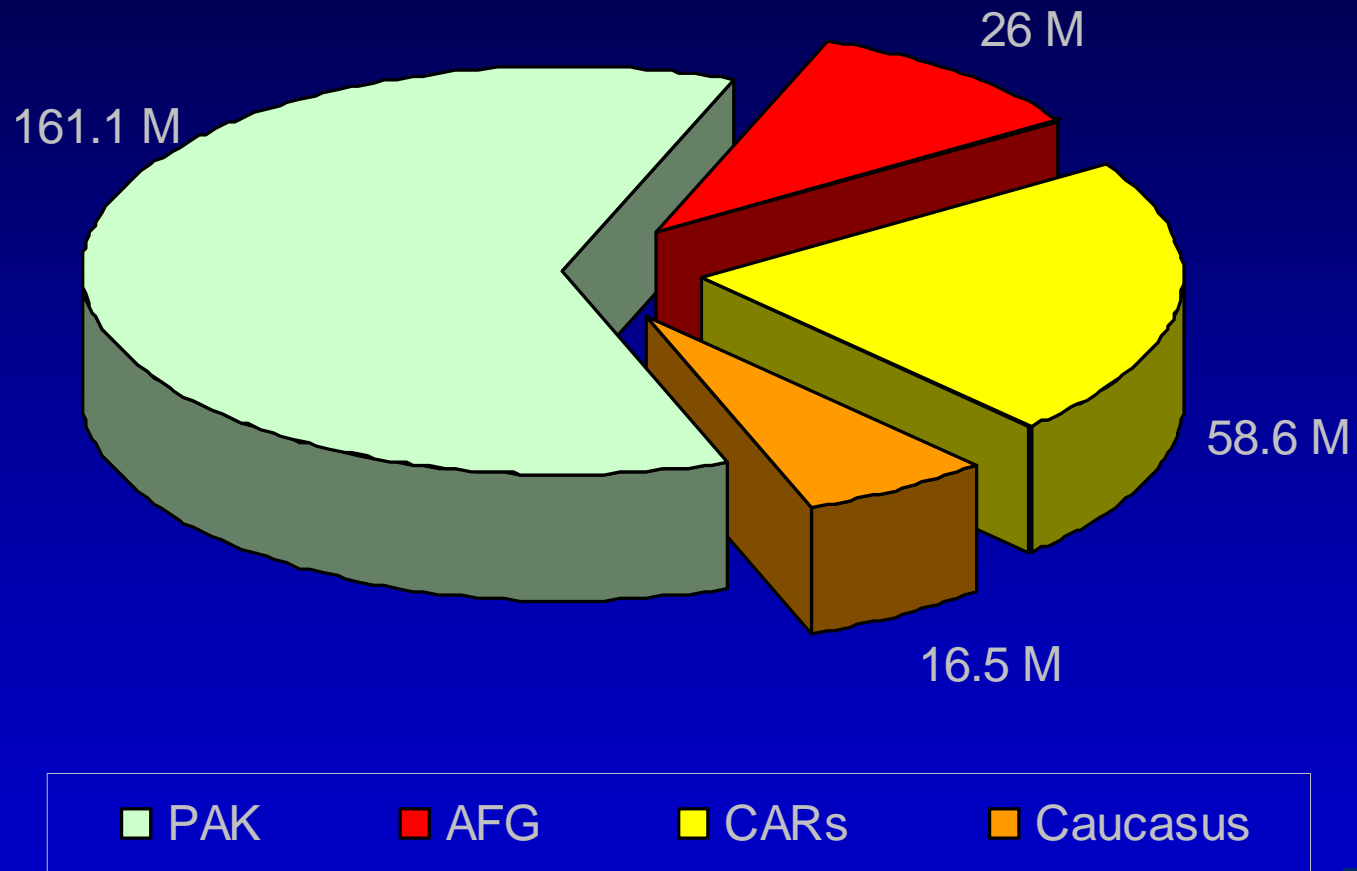

Source: UN, 2005

ADB

Central and West Asia Region

- Highly diverse group of 9 countries widely varying in resource endowment and development performance
- Crossroads between Asia and Europe characterized by diverse social and institutional structures
- Rich natural resources making region strategically important to global economy
- Physical connectivity and trade facilitation critical for more cost-effective market access

CWRD Strategic Directions

- Goal
 - To offer client countries relevant and timely services and products
- Focus on set of priority “business lines” to provide quality financial services and technical expertise
- Strategic drivers include:
 - Client needs and market conditions
 - Range of ADB services and products, including recent innovations
 - ADB track record and strengths

CWRD Priority Business Lines

Infrastructure

- Address energy and transport bottlenecks and encourage private sector participation and clean energy solutions
- Enhance domestic, regional, inter-regional connectivity and facilitate regional cooperation

CWRD Priority Business Lines

Social Services

Support to urban services and decentralization:

- Finance and expertise to small, medium and large city-based projects
- Assistance to expand social services

CWRD Priority Business Lines

Agriculture, Environment and Natural Resources

- Infrastructure and basic financial/technical services to improve operating conditions along production, processing and distribution chain.

- Production infrastructure and rural services focusing on water and land resource development/management
- Market infrastructure, agribusiness, market development

CWRD Priority Business Lines

Governance and Finance

Specialized services promoting reforms and greater efficiency/transparency across key sectors:

- Capital markets development
- Financial sector reform
- Trade facilitation and fiduciary oversight

CWRD Operating Approaches

- Simplicity and focus
- Programmatic approach – based on roadmaps
- Increased partnerships – with clients and financiers
- Enhanced teamwork across departments
- Combination of private and public interventions
- Faster processing, more focused due diligence
- More efficient implementation arrangements
- Sound portfolio management

2005 CWRD Loan Approvals

Total: \$1.0 billion for 19 loans

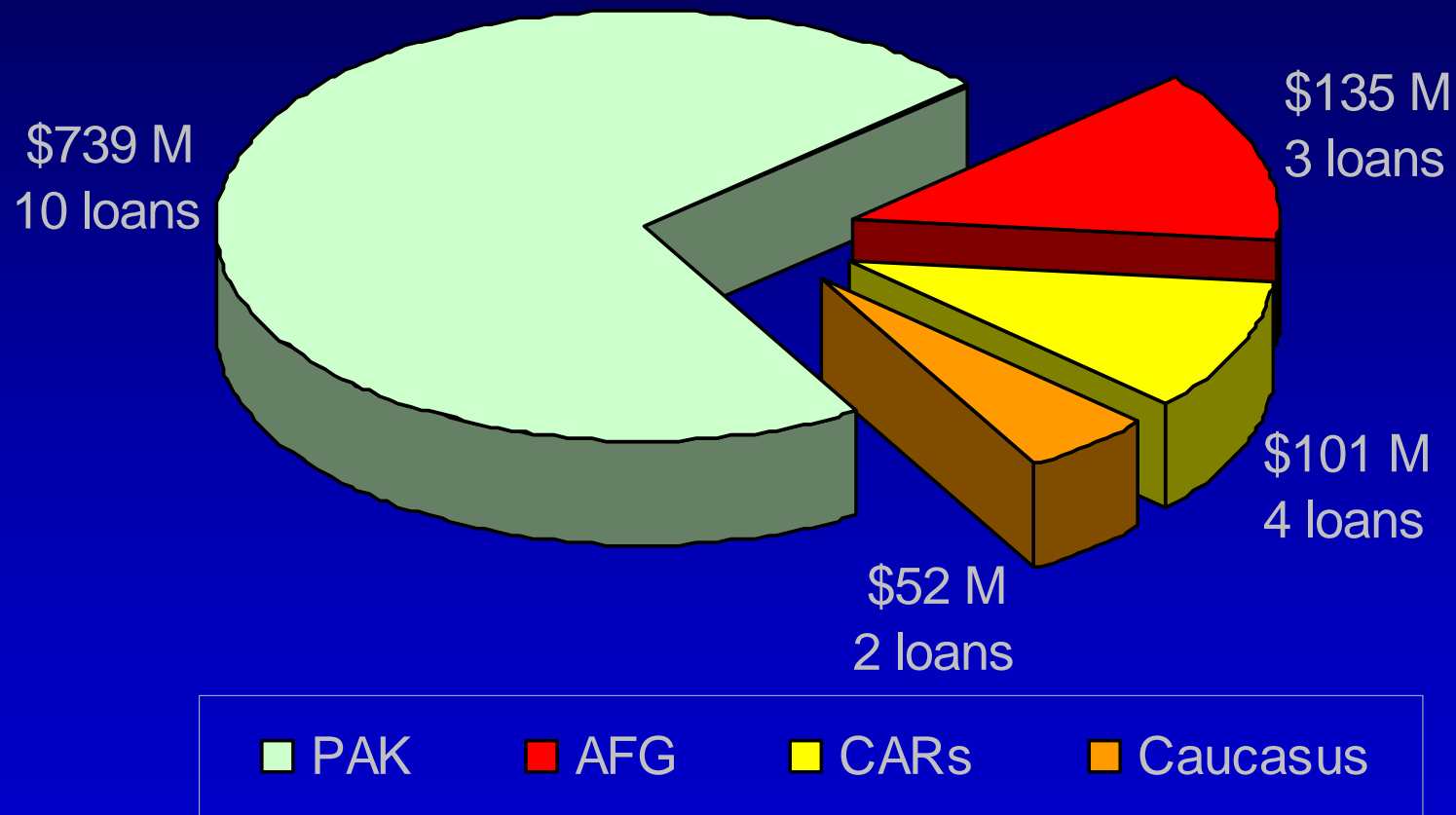

As of 31 December 2005

ADB

2006 CWRD TARGET Lending Program

Total: \$2.0 billion for 21 loans

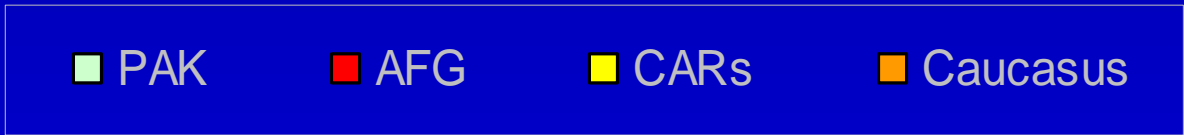
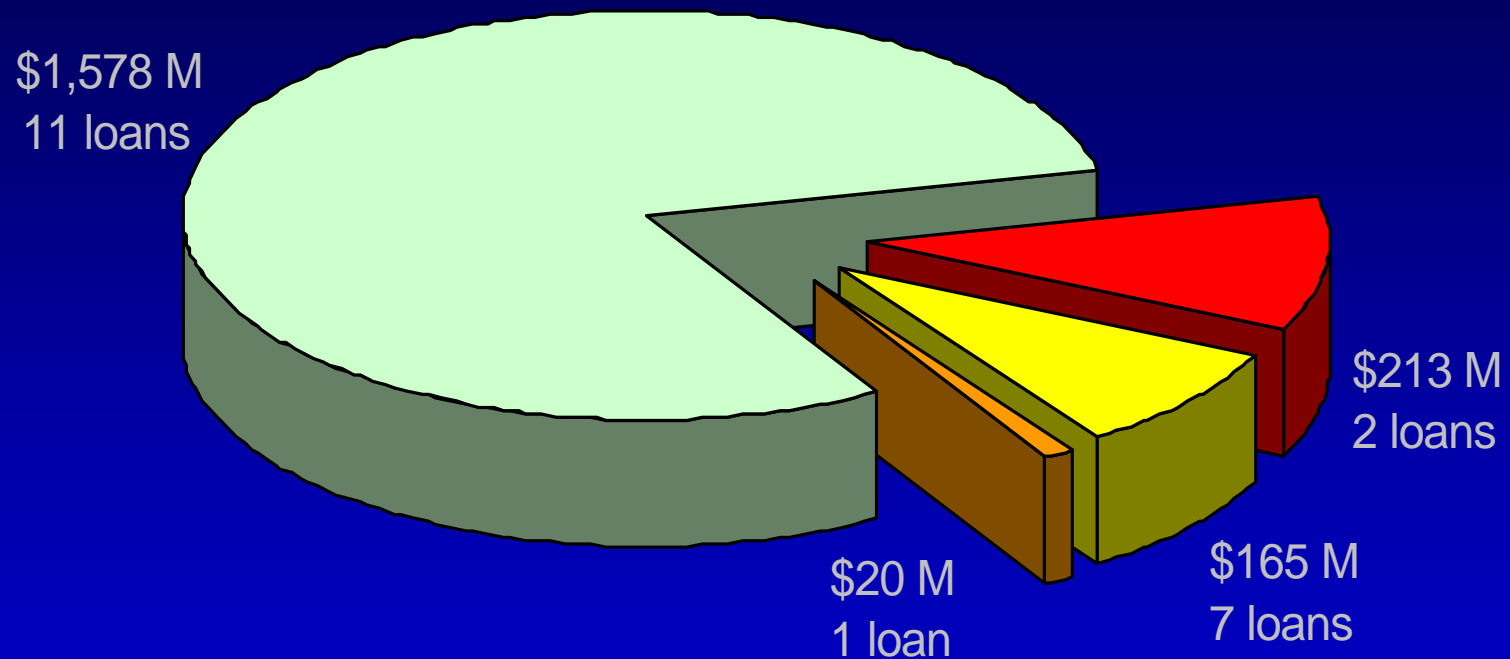

CWRD Loan Portfolio

Total: \$7.2 billion for 126 loans

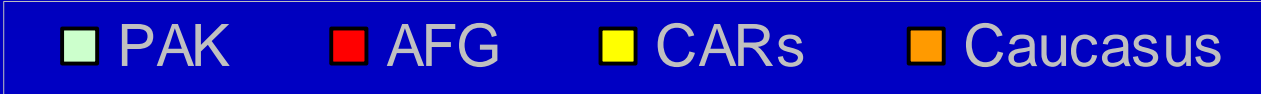
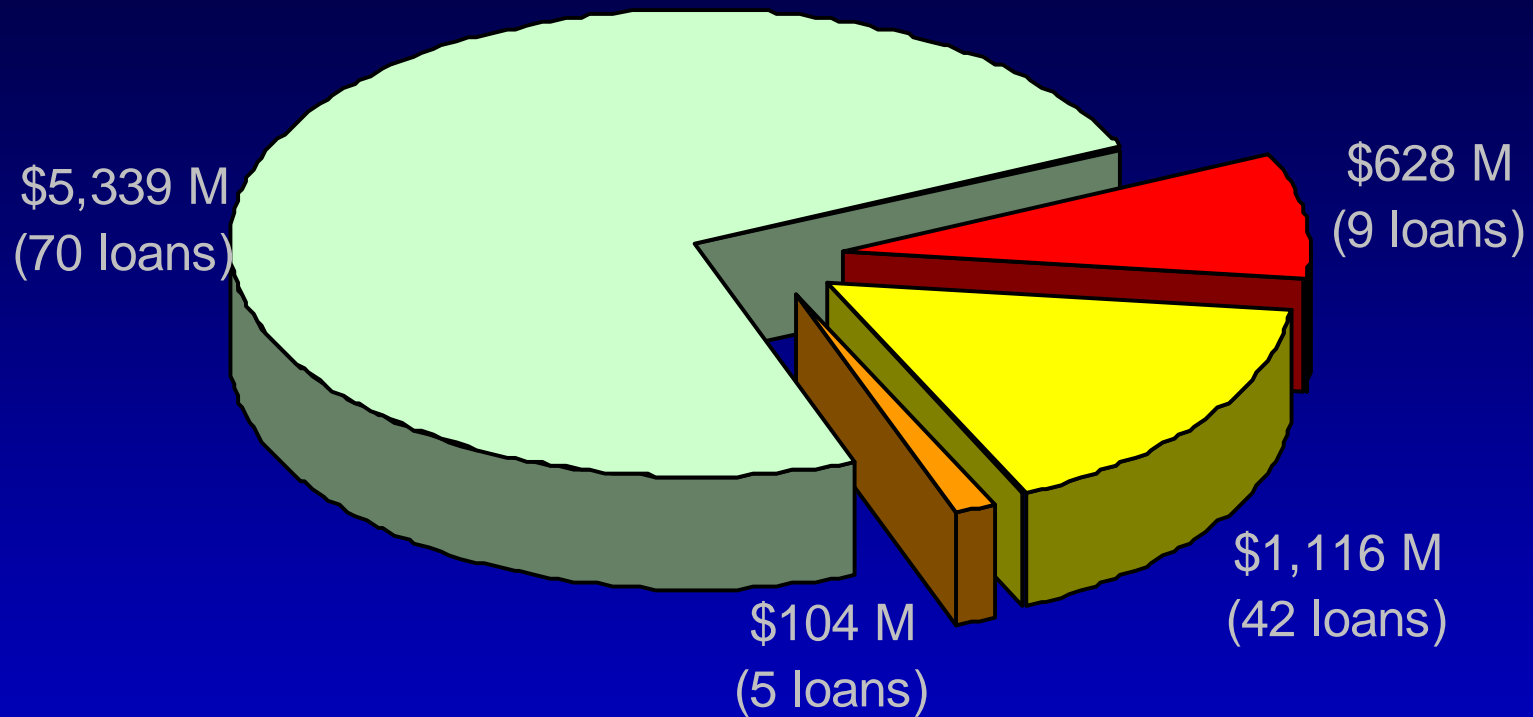

As of 31 December 2005



CWRD Technical Assistance Portfolio

Total: \$156.0 million for 196 TA projects

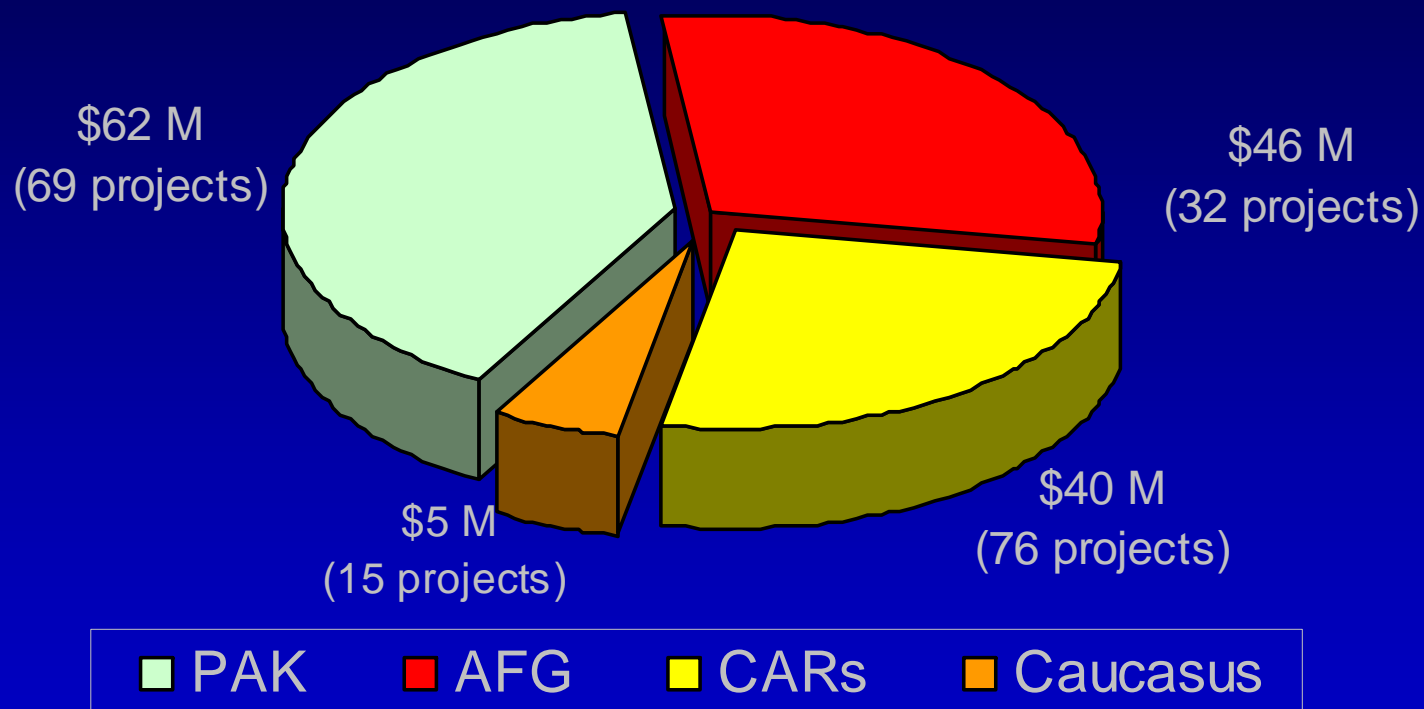

As of 31 December 2005

ADB

Regional Cooperation Initiatives

- **Central Asia Regional Economic Cooperation (CAREC)**
- **Subregional Economic Cooperation in South and Central Asia**
- **EG. Central and South Asia Transmission Interconnection Project**

Central Asia Regional Economic Cooperation (CAREC)

Aims to facilitate growth and poverty reduction through cooperation

- **4 priority areas:** Transport, Energy, Trade Policy and Trade Facilitation
- **8 participating countries:** Afghanistan, Azerbaijan, People's Republic of China (Xinjiang UAR), Kazakhstan, Kyrgyz Republic, Mongolia, Tajikistan, and Uzbekistan
- **Alliance of 6 multilateral institutions:** ADB, EBRD, IMF, IsDB, UNDP and World Bank
- **Only mechanism** in CARs that brings together 8 participating countries and 6 leading multilateral institutions within a single institutional framework

The logo for the Asian Development Bank (ADB), consisting of the letters 'ADB' in a white serif font on a dark blue rectangular background.



Operations in Pakistan

Key Focus

- Urban services and infrastructure
- Transport corridors and energy security
- Rural finance and production infrastructure
- Capital markets, finance, trade and PPP

Key Challenge

- Ensure sustained growth and support social stability

Operations in Afghanistan

Key Focus

- Transport and Energy
- Rural infrastructure

Key Challenges

- Effective and focused support to nation building and economic reconstruction
- Capacity building

Operations in CARs: Kazakhstan, Kyrgyz Republic, Tajikistan, Uzbekistan, [Turkmenistan]

Key Focus

- Urban services
- Transport and energy
- Agriculture and rural development
- Education and health services
- Private sector development

Key Challenges

- Combining financing with support for policy, governance and institutional reforms
- Effective promotion of public-private partnerships
- Catalyzing private investments
- Fostering regional cooperation

Operations in Caucasus: Armenia, Azerbaijan, [Georgia]

Key Focus

- Private sector development
- Regional cooperation to facilitate transit, trade and energy networks
- Rural development

Key Challenges

- Effective promotion of public-private partnerships
- Tackling employment and rural poverty
- Fostering regional cooperation

Thank You

ADB